

SDI at Work

Spatially Enabling Business Processes

Ezra Dessers

Business processes



- Spatial data access, use and exchange takes place in a network of business processes, within and between organisations
 - Reference for the effectiveness of an SDI
 - Supportive nature of infrastructures
 - Supporting the goals of the users
- realisation of SDI goals takes place in the processes of the SDI stakeholders



Spatial enablement

- SDI: means
- Spatial enablement: ends



Global Geospatial Conference 2012

Spatially Enabling Government, Industry and Citizens

Québec City, Canada, 14-17 May 2012

Two levels of analysis

- Inter-organisational
 - Comparison of the 4 cases
- Intra-organisational
 - Comparison of the embedded cases, i.e. selected organisations within each case

← This presentation

1. Task division

The extent to which the different steps in the execution of (an instance of) the process are functionally distributed across multiple organisations.

The Zoning Plans Case

- Single government organisation responsible for every step in the development of a specific zoning plan.

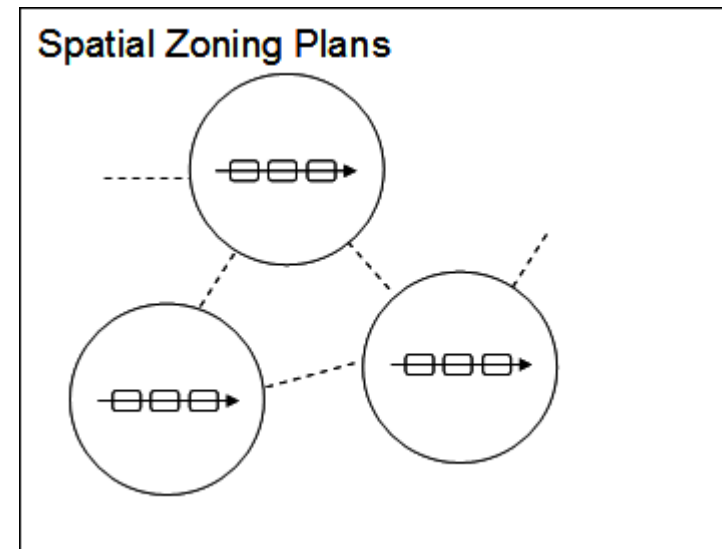

The Addresses Case

- Every organisation mainly manages its own address data
- Within the context of its various activities (like population registration, economic policy, ...).

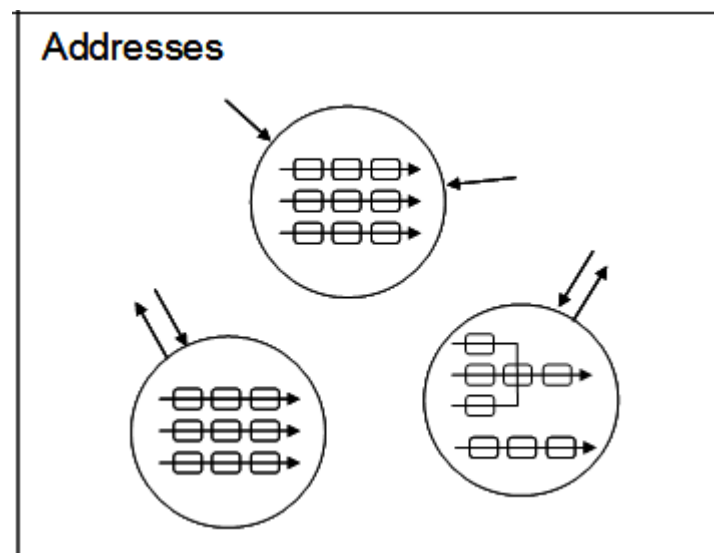

The Traffic Accidents Case

- Every organisation represents a step in the inter-organisational process chain. (Registration, geocoding, statistics, analysis, ...) High fragmentation of the process steps across multiple organisations.

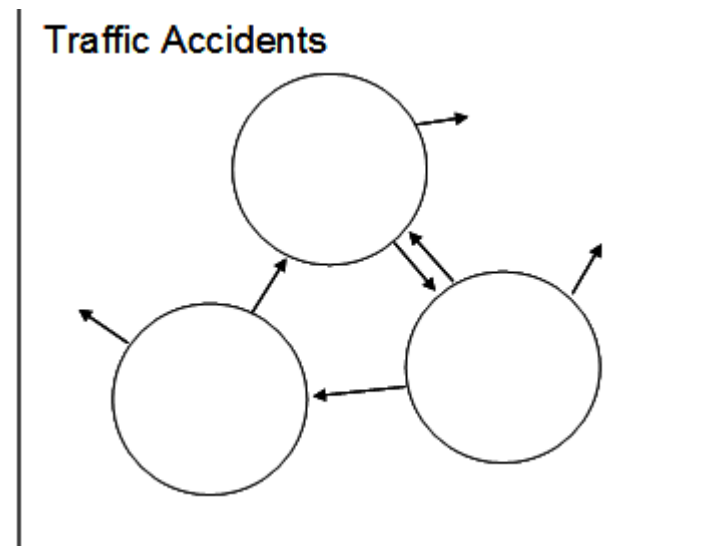

The Flood Maps Case

- Each organisation is mainly in charge of its own (sub-)processes from a to z, although at a more general level, the inter-organisational task division with regard to actual water management is still largely organised along functional and administrative lines, which also seems to impact the flood maps process.

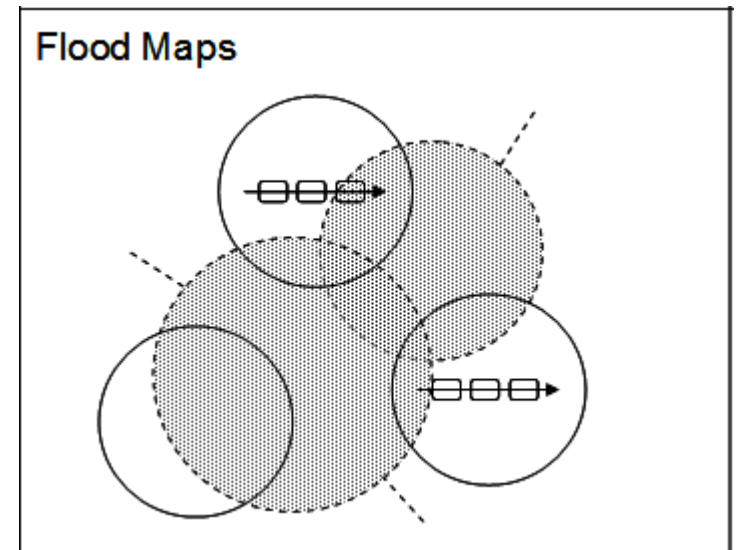

2. Coordination

The level of central control and steering of the inter-organisational process

The Zoning Plans Case

- Rapidly changing Flemish legislation determines procedure and requirements
- Actual development of a zoning plan mainly in the hands of the organisation that initiates the procedure.
- Alignment with other organisations via consultation (part of the legal procedure).

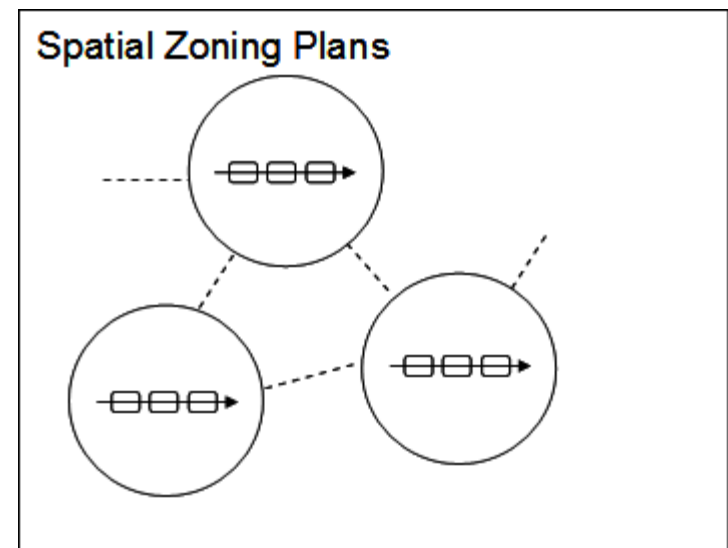

The Addresses Case

- Inter-organisational coordination initiatives focus rather on the management of thematic data (population, enterprises, environmental permits).
- Actual inter-organisational coordination of address data management is very limited

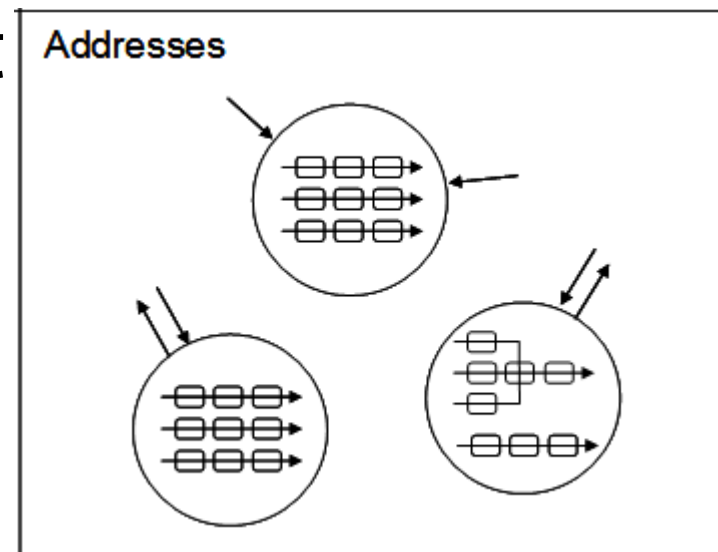

The Traffic Accidents Case

- Many coordination problems (duplication of work, discussions about data ownership, long total lead time)
- Organisations have little influence on the execution of steps by other organisations. problems propagate through the process chain.
- Alignment efforts mainly consists of bilateral arrangements or consultation

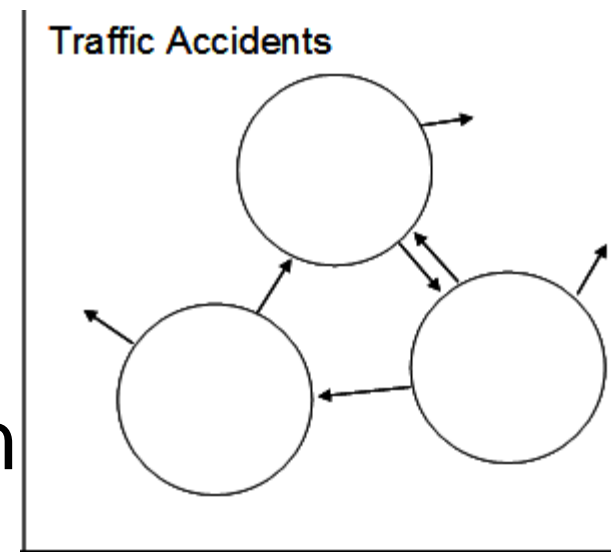

The Flood Maps Case

- Each organisation is mainly in charge of its own flood maps related activities
- Frequent inter-organisational consultation
- More general: extensive consultation structures at different levels of catchments to ensure that all functionally specialised authorities, administrations and interest groups work together.

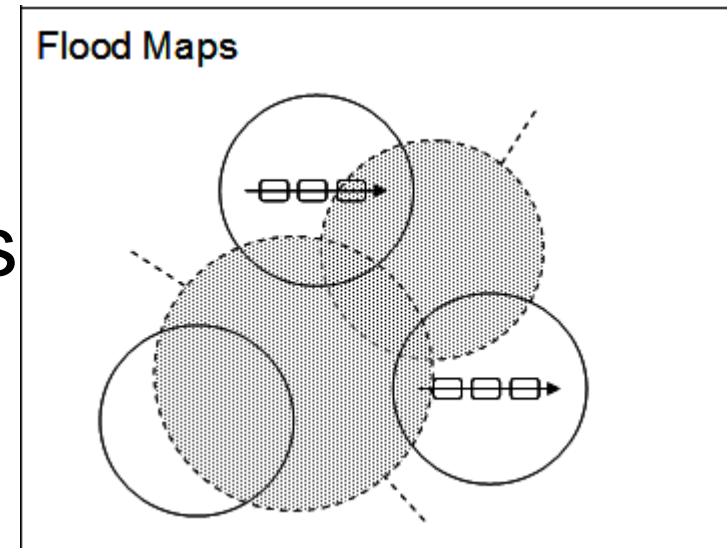

3. Spatial data function

the degree of concentration of the spatial data related activities in the inter-organisational process.

The Zoning Plans Case

- Each organisation is responsible for own spatial data related activities.
- No central organisation takes care of (parts of) the spatial data related activities.
- A guideline for digital exchange of plans
- Flemish Administration performs limited coordinating task regarding data exchange

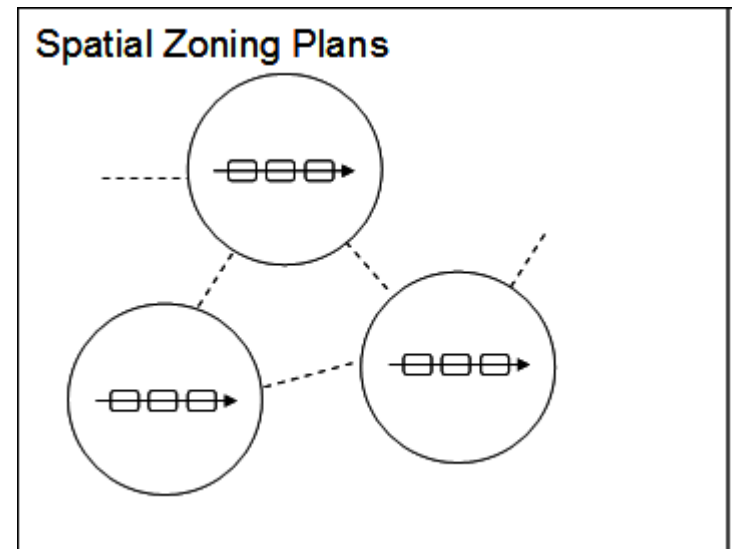

The Addresses Case

- Central Reference Address Database (CRAB) created and managed by the Flemish SDI Agency (AGIV)
- Still* rarely used in actual address management
- Mainly used as thematic layer in org's GIS
- Geocoding & use of geocoded addresses largely separated from thematic processes

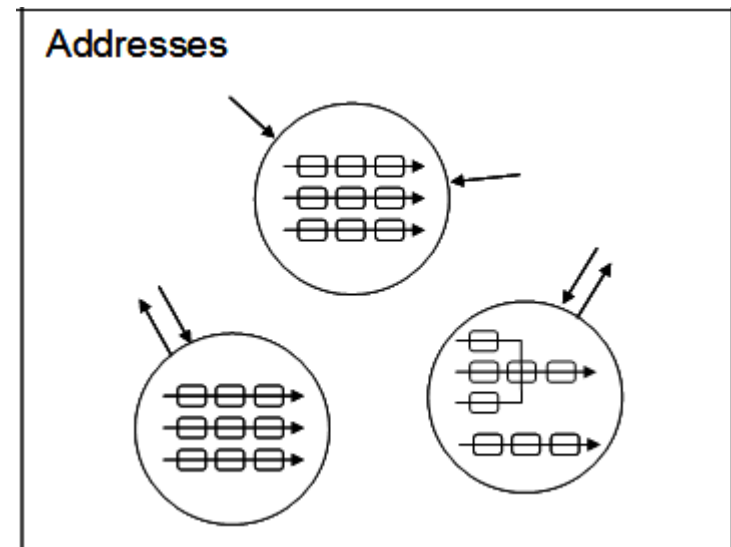

* Authentic source since June 2011, GRAB initiative

The Traffic Accidents Case

- Multiple organisations undertake uncoordinated efforts for geocoding traffic accidents locations, thereby partly duplicating one another's work.
- Flemish Administration & provinces coordinate geocoding (end of chain)

Further coordination efforts (Federal Police) in preparation

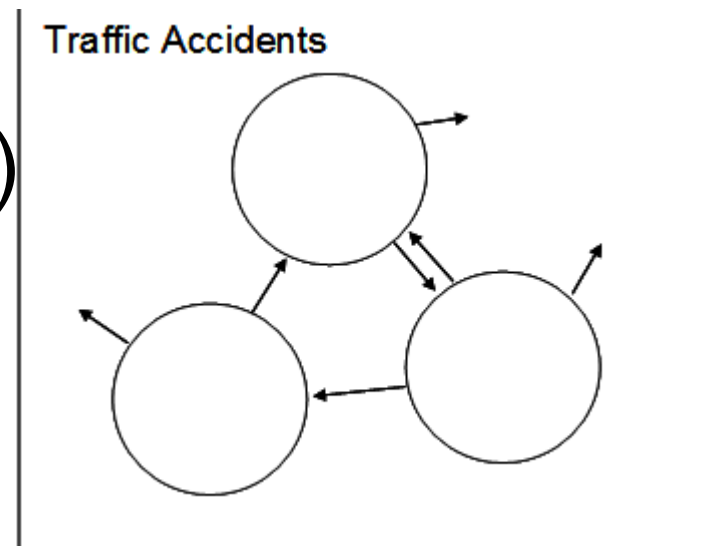

The Flood Maps Case

- Each organisation is largely responsible for the spatial data related activities with regard to their flood map related tasks
- Flemish Environment Agency de facto coordinates part of the spatial data collection

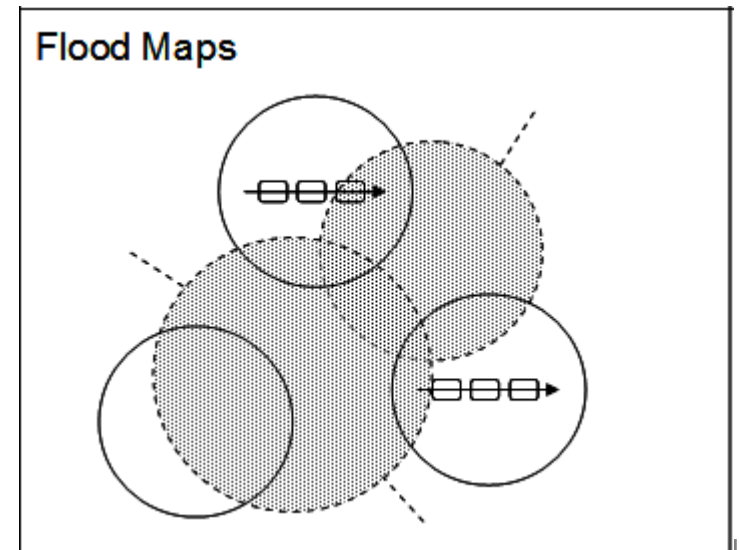

Organising business processes

■ Task division

- Functional
- Process-based

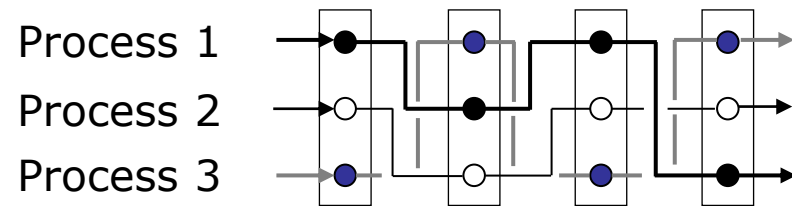

■ Coordination

- Centralised
- De-centralised

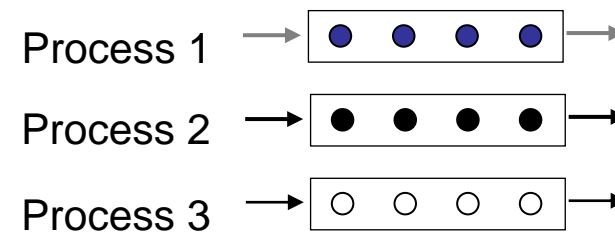

■ Allocation of spatial data related activities

- Concentrated
- De-concentrated

Spatial enablement



- In terms of:
 - Efficiency of Access
 - Intensity of Use
 - Degree of Sharing
- High
 - The Zoning Plans Case
 - The Flood Maps Case
- Low
 - The Addresses Case
 - The Traffic Accidents Case

- RQ: Impact of process structure on spatial enablement
- Hypothesis: higher level of spatial enablement if
 - Process-based task division
 - De-centralised coordination
 - Embedded spatial data function

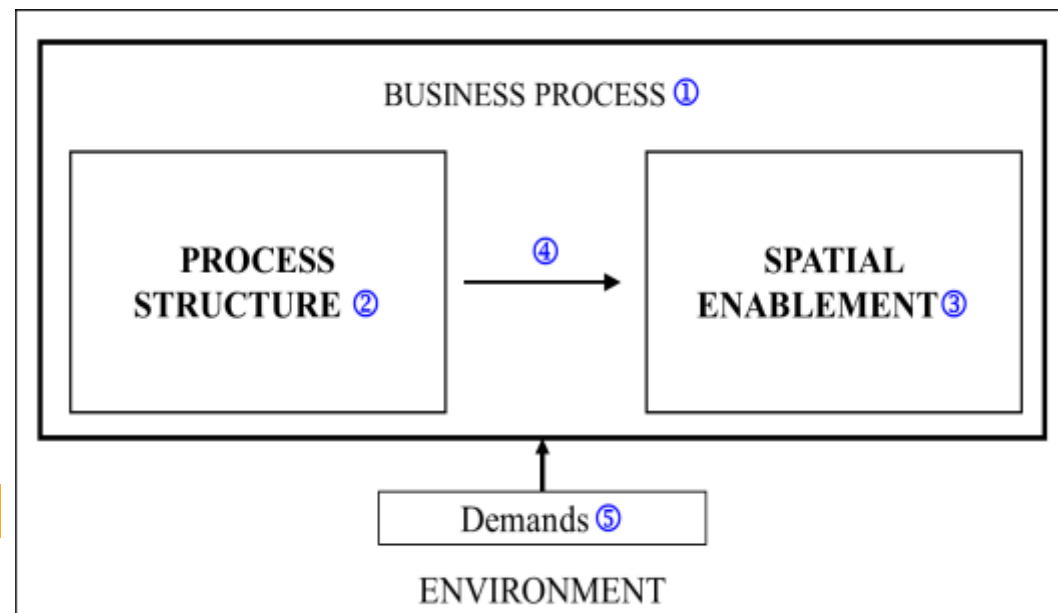

Comparative analysis

Spatial zoning plans

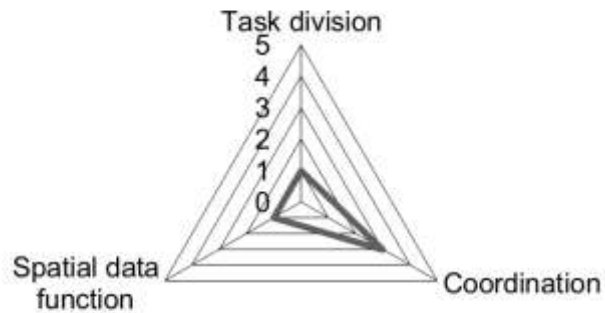

(Spatial enablement: High)

Flood maps

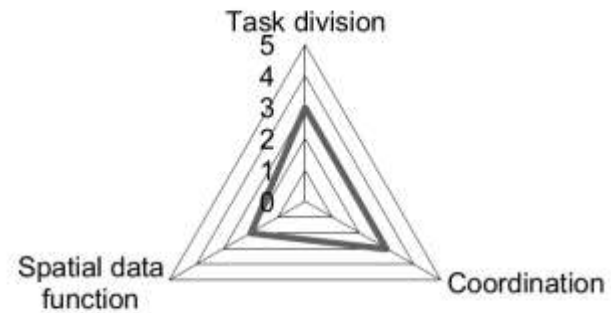

(Spatial enablement: High)

Addresses

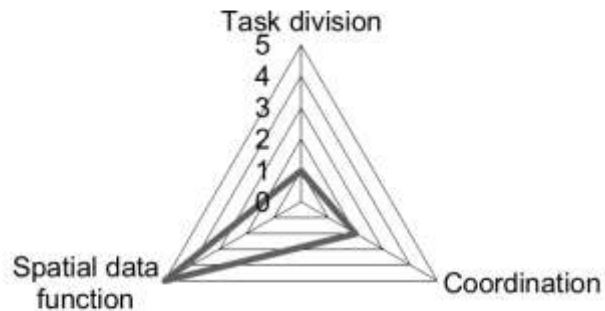

(Spatial enablement: Low)

Traffic accidents

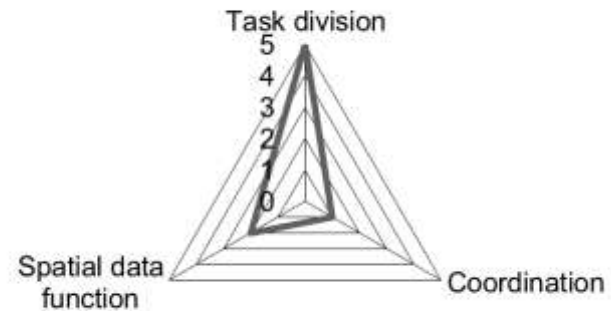

(Spatial enablement: Low)

Results



- An integrated process with an embedded spatial data function could be linked to a high level of *spatial enablement*.
- Fragmented processes without equivalent coordination efforts (Traffic accidents case), or the separation of the spatial data function from the process (Addresses case), seem to lead to lower levels of *spatial enablement*.
- But: intra-org analysis might conceal differences between the sub-processes or process instances that take place within the various organisations involved.

Zoning plans case



■ Province of Limburg

High internal task division with much outsourcing, many hierarchical levels, separation of the spatial data function

■ Flemish Spatial Planning Department

Limited internal task division, flat departmental structure, medium separation of spatial data function

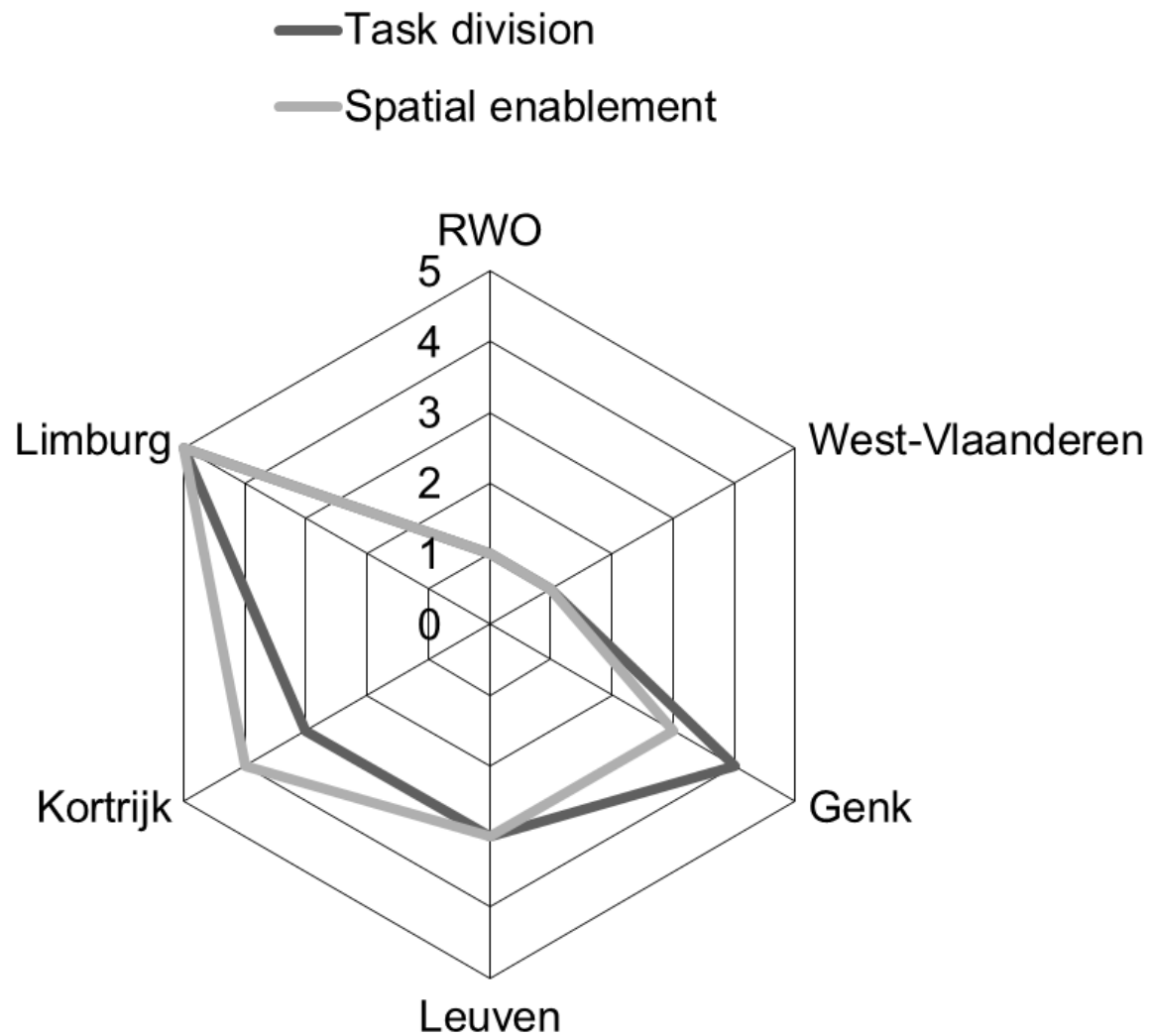

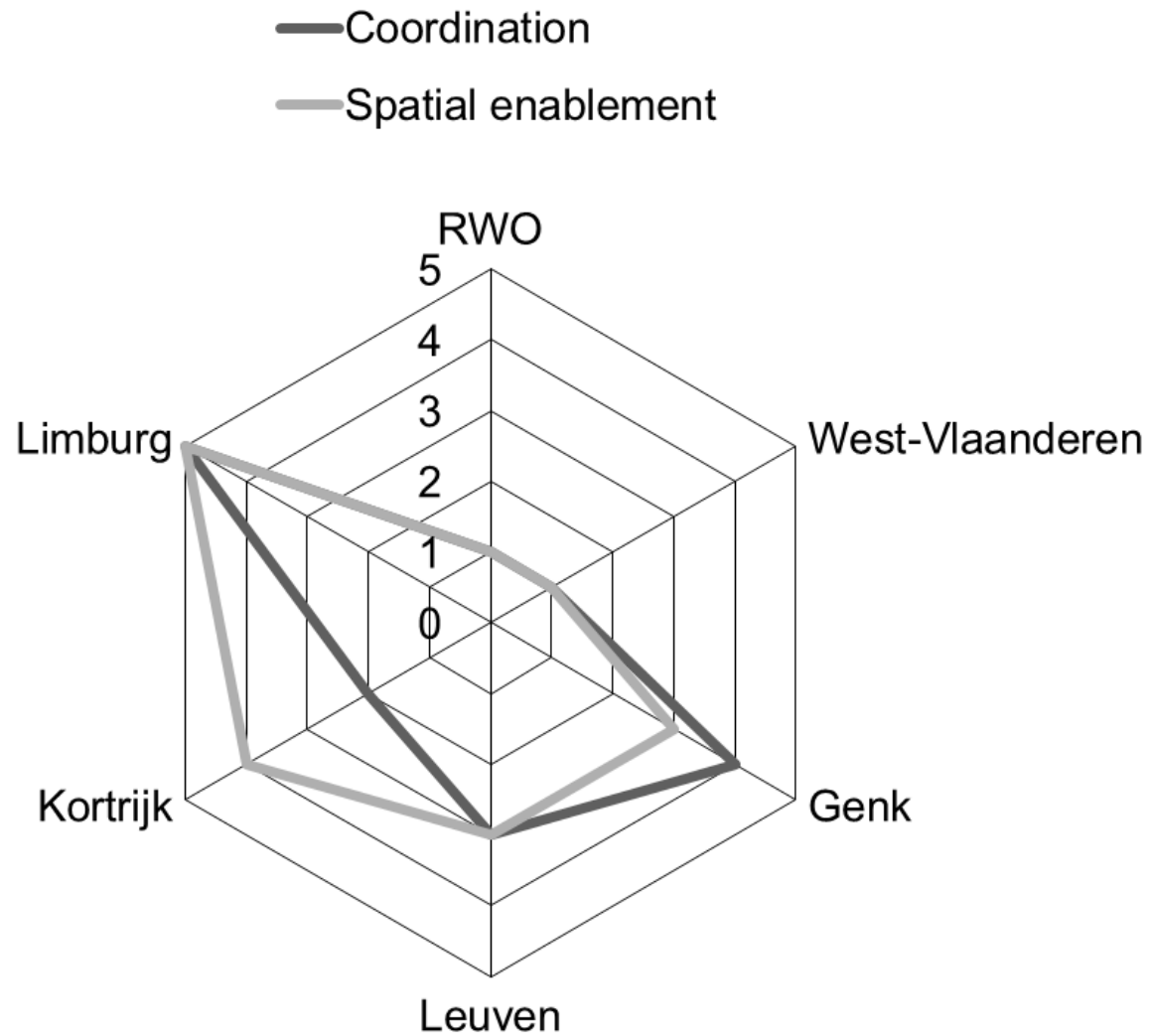

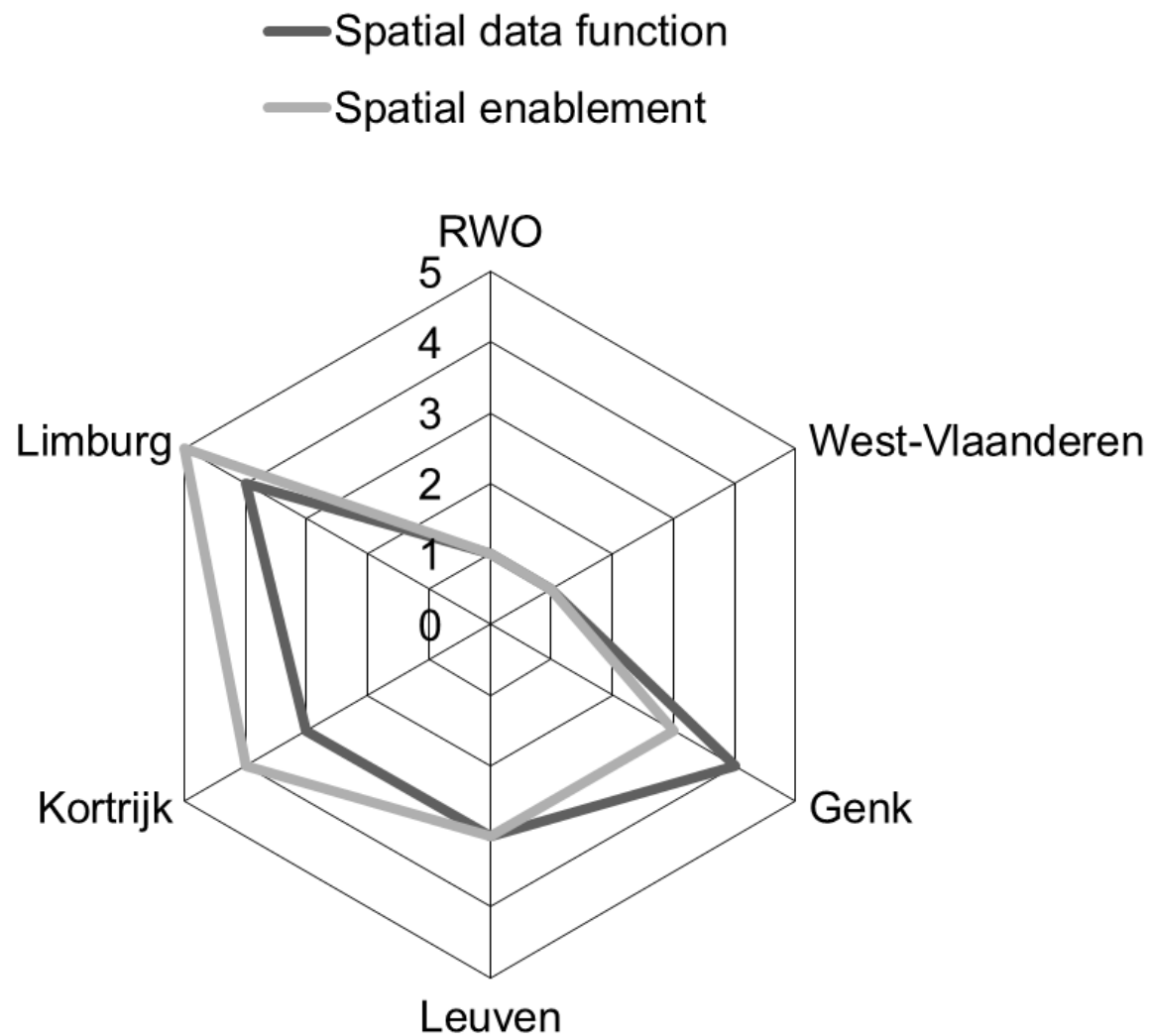

General results



- De-concentration, de-centralisation, embedding spatial data activities contributes to spatial enablement
- More important for processes that require flexibility & innovation (as opposed to more routine & standardised processes)
- Other demands:
 - Appraisal of spatial data as a strategic asset (
 - Importance of the process for the organization

- SDI development should take process characteristics into account.
 - Integration in existing processes
 - Redesign processes
- De-concentration, de-centralisation
 - Inspire principles
 - SDI Flanders principles

→ But has to be put into practice!
- Embed spatial data handling in processes (as opposed to separate spatial data initiatives)

Thank you



Ezra Dessers
Centre for Sociological Research
Katholieke Universiteit Leuven
+32 16 32 34 57
ezra.dessers@soc.kuleuven.be
www.spatialist.be